

LA CONFEZIONE CONTIENE

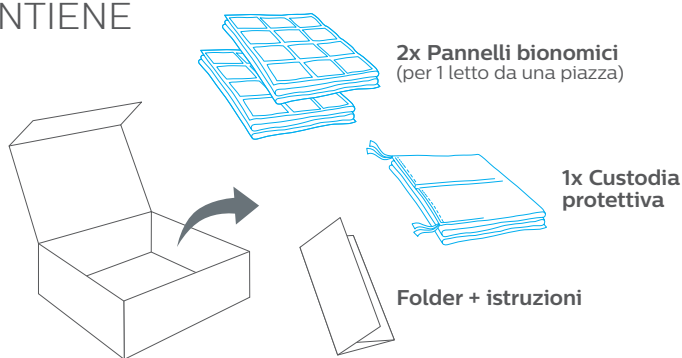

Per un letto a 2 piazze è necessario aggiungere 1 set completo.

COME INIZIARE AD UTILIZZARE **LifeBion**

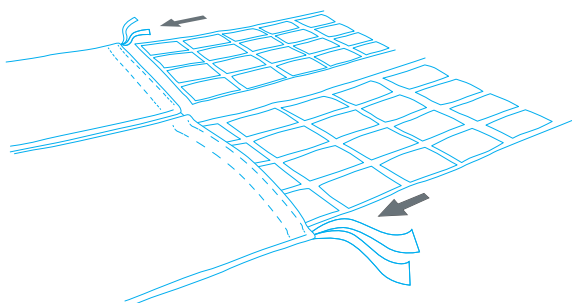

Estrarre i due pannelli bionomici dalla confezione e inserirli in ognuna delle due tasche della custodia protettiva contenuta nella confezione.

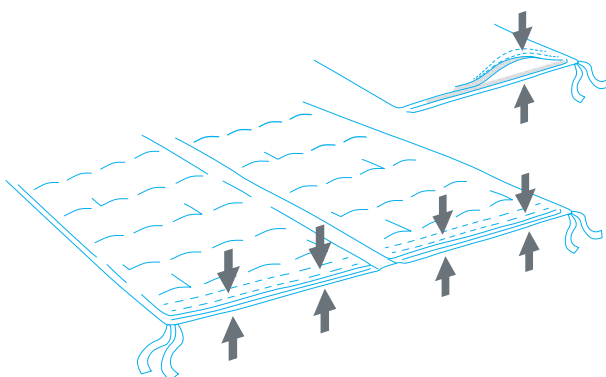

Fissarli alla custodia protettiva facendo aderire l'apposito velcro dopo aver rimosso la striscia apposta sullo stesso.

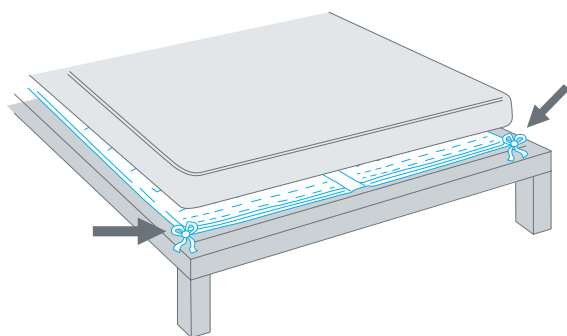

Posizionare LifeBion così preparato sotto il materasso, ancorandolo alla struttura del letto (doghe, rete ecc.) servendosi degli appositi lacci presenti sulla custodia protettiva stessa.

*I pannelli bionomici LifeBion non sono lavabili. La custodia protettiva, invece, è lavabile, attenendosi alle istruzioni di lavaggio riportate sull'etichetta applicata su di essa.
Nota: eventuali imperfezioni (es. granelli fuori dalle loro sedi) non compromettono la qualità e l'efficacia di LifeBion.*

ENERGIA, ARMONIA, BENESSERE!

LifeBion
with **magma13**
Intelligent energy technology

Made by **propacare®**

Engineered with **SOLS**



www.lifebion.com



THE PACKAGE CONTAINS

EL PAQUETE CONTIENE

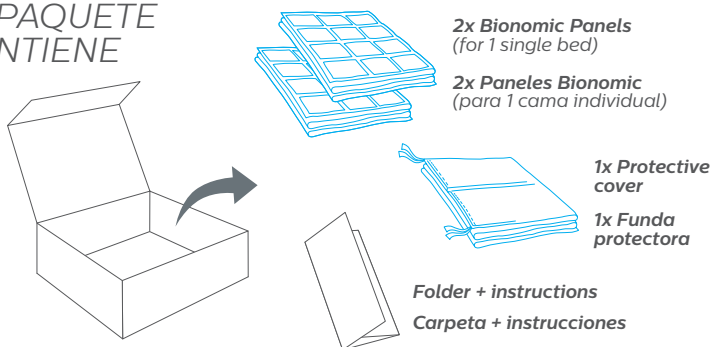

For a double bed you need to add 1 complete set.

Para una cama doble es necesario añadir 1 juego completo.

HOW TO START USING

CÓMO EMPEZAR A USAR

LifeBion

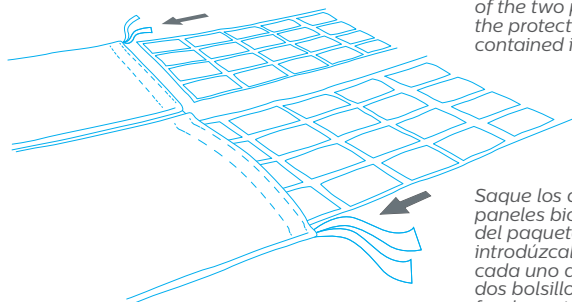

Take the two bionomic panels out of the pack, and insert them into each of the two pockets of the protective cover contained in the pack.

Saque los dos paneles bionómicos del paquete e introdúzcalos en cada uno de los dos bolsillos de la funda protectora que contiene el paquete.

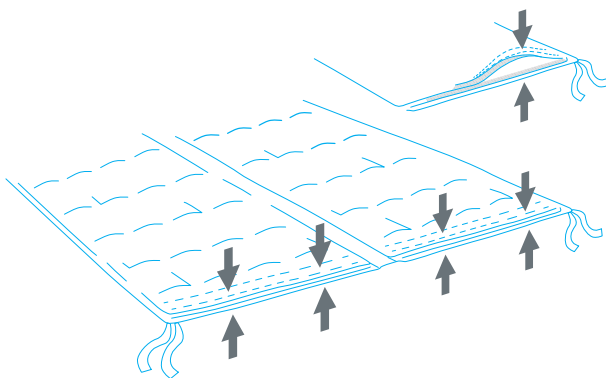

Attach them to the protective cover by attaching the velcro after removing the protective strip.

Fíjelos al estuche protector fijando la tira de velcro después de haber retirado la tira protectora.

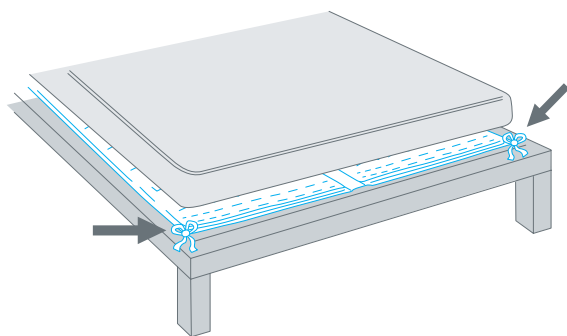

Place LifeBion prepared in this way under the mattress, anchoring it to the bed frame (slats, bed base, etc.) using the ties on the protective cover itself.

Coloque el LifeBion preparado de este modo bajo el colchón, anclándolo al somier (listones, base de la cama, etc.) mediante las ataduras de la propia funda protectora.

The LifeBion bionomic panels are not washable. The protective cover, on the other hand, is washable, following the washing instructions on the label attached to it. *Note: any imperfections (e.g. grains outside their seats) do not impair the quality and effectiveness of LifeBion.*

Los paneles bionómicos LifeBion no son lavables. La funda protectora, en cambio, sí es lavable, siguiendo las instrucciones de lavado que figuran en la etiqueta adherida a la misma. *Nota: las posibles imperfecciones (por ejemplo, granos fuera de sus asientos) no merman la calidad y eficacia de LifeBion.*

ENERGY, HARMONY,
WELL-BEING!

¡ENERGÍA, ARMONÍA,
BIENESTAR!

LifeBion
with magma13
intelligent energy technology

Made by propacare®

Engineered with SOLS



www.lifebion.com

Aunque LifeBion sea de larga duración, compruebe la normativa de gestión de residuos de su municipio en caso de eliminación.

Even if LifeBion is long-life, please check your municipality's waste management regulations when disposing of it.